

RSS Series — Panel Mount Solid State Relays

Key features of the RSS series include:

- Input status LED Indicator
- Dual SCR output
- Direct bond copper substrate
- Internal transient protection – built-in snubber
- EMC compliant (level 3)
- Photo isolation
- 1200 volt blocking voltage
- 4000 volt optical isolation
- Zero voltage turn-on
- 100% tested at rated current
- High surge capability
- Optional finger-safe terminal cover (RSS-CVR)



10, 25, 50, 75, 90A Current Ratings
48V AC to 660V AC Output Ratings

E
Relays



Input Specifications	Series	RSSDN	RSSAN
	Voltage Range	4 to 32V DC	90 to 280V AC
	Input Current	current regulated (10mA)	
	Pick Up Voltage	4V DC	90V AC
	Drop Out Voltage	1V DC	10V AC
	Dielectric Strength (Input-Output-Base)	4000 RMS (min)	4000 RMS (min)
	Capacitance (Input to Output)	8pF	8pF
	Rev. Voltage Protection	Yes (-32VDC)	N/A

Output Specifications	Current (continuous)	10A	25A	50A	75A	90A
	1-Cycle Surge Current	150A	300A	750A	1000A	1200A
	1-Second Surge Current	30A	75A	150A	225A	300A
	Minimum Holding Current	50mA	50mA	100mA	100mA	100mA
	Voltage Drop at Rated Current	1.6V (maximum)				
	Voltage Range	48 - 660V AC				
	Contact	1 Form A (SPST-NO)				
	Over Voltage Rating	1200 PIV				
	Frequency Range	47 to 80Hz				
	Off-State Leakage at Rated Voltage	20mA (maximum)				
	Turn-On Time	1/2 cycle @ 60Hz				
	Turn-Off Time	1/2 cycle @ 60Hz				
	Zero Voltage Switching	Yes				
	Static DV/DT	200V/μsec				
Commutating DV/T	Snubbed for 0.5 power factor at rated load					

Part Numbers

Part Numbers: RSS Series

Continuous Output Current	DC Input	AC Input
10A	RSSDN-10A	RSSAN-10A
25A	RSSDN-25A	RSSAN-25A
50A	RSSDN-50A	RSSAN-50A
75A	RSSDN-75A	RSSAN-75A
90A	RSSDN-90A	RSSAN-90A



The fingersafe cover is part no. RSS-CVR.

Recommended Loads

Transformer Loads

Transformer loads sometimes result in severe inrush current when the transformer saturates during the first cycle. Use a relay rated for this surge, which has a 1/2 cycle surge current greater than the maximum applied line voltage ÷ the transformer's primary resistance (approximately 10x rated current).

Recommended Loads

SSR Rating	at 120V AC	at 240V AC
2A	150VA	300VA
4A	200VA	400VA
10A	500VA	1KVA
25A	1KVA	2KVA
50A	2KVA	4KVA

Heater Loads

When using solid state relays for driving heaters where the load is switched on and off rapidly and continuously, severe thermal stress will result. In such cases, use an SSR relay at no more than 75% of the rating.

Recommended Loads

SSR Rating	at 120V AC	at 240V AC
2A	250W	500W
4A	400W	800W
10A	1KW	2KW
25A	2KW	4KW
50A	3KW	6KW

Solenoid Valves and Contactors

RSS relays use high-noise immunity circuitry with a snubber to handle the electrical noise generated by inductive loads.

Recommended Loads

SSR Rating	at 120V AC	at 240V AC
2A	250W	500W
4A	400W	800W
10A	900W	1,800W
25A	2,100W	4,200W
50A	3,800W	7,500W

RSS series relays provide a highly reliable means of switching AC loads when applied properly. Read the following technical notes prior to installing IDEC's quality solid state relays.

UL Motor Load Ratings

Part Number	120V	240V	480V
10A	1/2	3/4	3/4
25A	1/2	3/4	3/4
50A	3/4	1 1/2	1 1/2
75A	3/4	5	5
90A	3/4	5	5

Lamp Loads

Zero voltage switching is ideal for driving incandescent lamps, since the cold filament will not be subjected to a large inrush current. Using a zero-switched SSR will reduce inrush current and prolong lamp life.

Recommended Loads

SSR Rating	at 120V AC	at 240V AC
2A	2A	2A
4A	3A	3A
10A	1KW	2KW
25A	2KW	4KW
50A	3KW	6KW

Internal Circuit Block Diagram

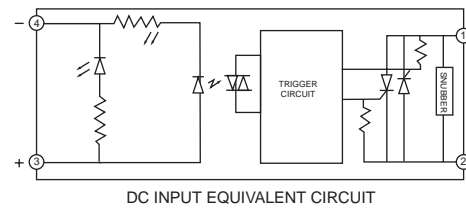
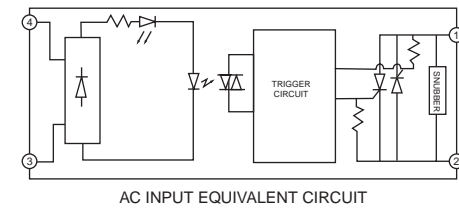

Technical Notes

Environment

Do not install SSRs near sources of excessive heat. Make sure applications are dry and well ventilated.

If SSRs must be installed in an environment subject to high temperatures or poor ventilation, or if SSRs are mounted collectively, reduce the load current so that it does **not** approach the ambient temperature-load current recommendation. (See the Temperature Derating Curves on the following page.)

When SSRs are used with inductive loads, suppress the inrush current to half of the peak surge current.

Heat Sinks

Heat sinks are recommended for 10, 25, 50, 75, and 90 amp rated solid state relays depending on ambient temperature and mounting position. The recommended heat sink dimensions and material are shown in the table:

Output Rating	Dimensions	Material
10A	12" x 12" x 1/8"	Aluminum (black anodized)
25A	12" x 12" x 1/8" (DC/AC)	Aluminum (black anodized)
25A	15" x 15" x 1/8" (AC/AC)	Aluminum (black anodized)
50A	15" x 15" x 1/8"	Aluminum (black anodized)
75A	17" x 17" x 1/8"	Aluminum (black anodized)
90A	17" x 17" x 1/8"	Aluminum (black anodized)

E

Relays

Using a thermal compound between the base of the SSR and the heat sink for heat dissipation is recommended.

Wiring

Locate SSRs as far from motor leads as possible to prevent malfunction from induced current.

Use shielded wires for input leads when they are exposed to a source of induced current.

Mounting

Provide sufficient ventilation.

Use #6 – 32 screws, flat washers, and lock washers to secure mounting on heat sinks.

Vertical mounting is recommended to allow air to flow unimpeded. Horizontal or inverted mounting is possible, but the SSR must be derated according to the derating curves on the following page.

Additional Information

Do not exceed the load voltage and current specifications.

A small-capacity load may not turn off due to the leakage current present after the SSR has turned off. If this is the case, use a resistor in parallel with the load to shunt the leakage current.

Observe the polarity of input terminals. Failure to do so may cause damage to the SSR.

When the SSR output is subjected to a higher than rated voltage, a varistor or other element should be connected to the output terminals to absorb the over-voltage.

When the input signal contains a ripple voltage, the lowest ripple amplitude should exceed the minimum pick-up voltage of 4V.

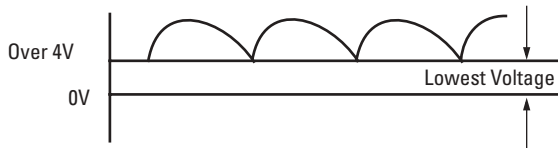

Temperature Derating Curves: RSS Series

Derating Curve
10-Amp and 25-Amp

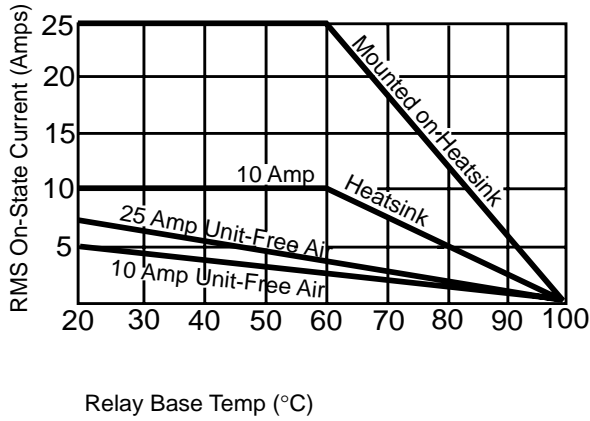

Derating Curve
50-Amp, 75-Amp, and 90-Amp

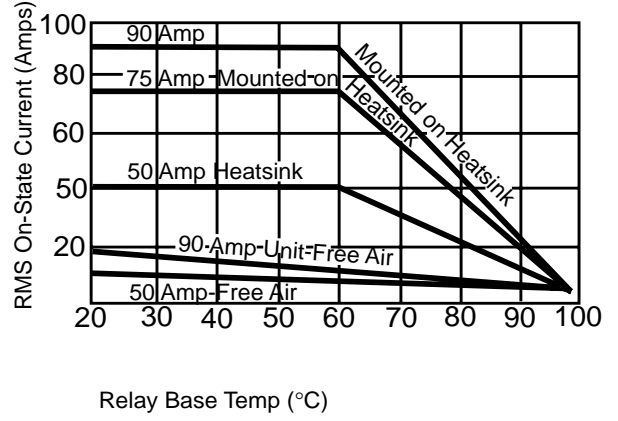

For information on heat sink size, refer to the Technical Notes on the previous page.

E
Relays

RSS Dimensions

RSS Series

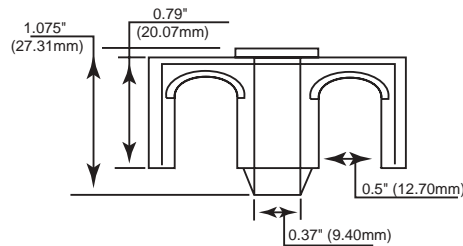
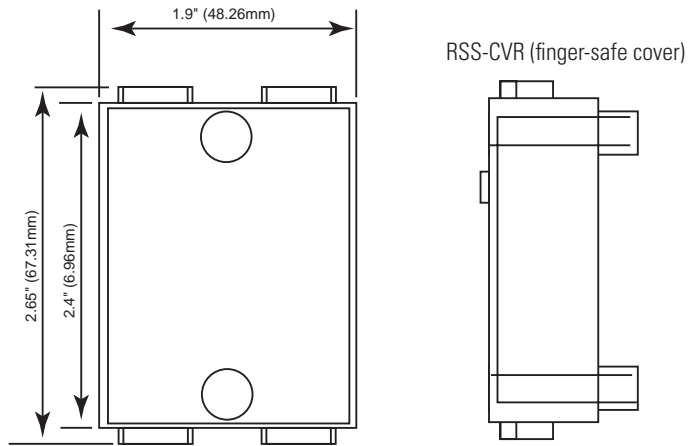
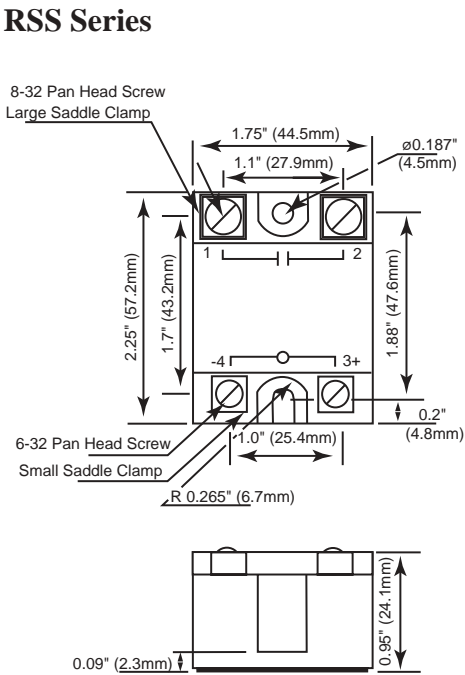

Material: Polycarbonate-Clear

